

System 9000

Bleacher seating system

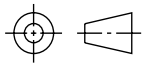

Seating Elements

Seating Unit - D

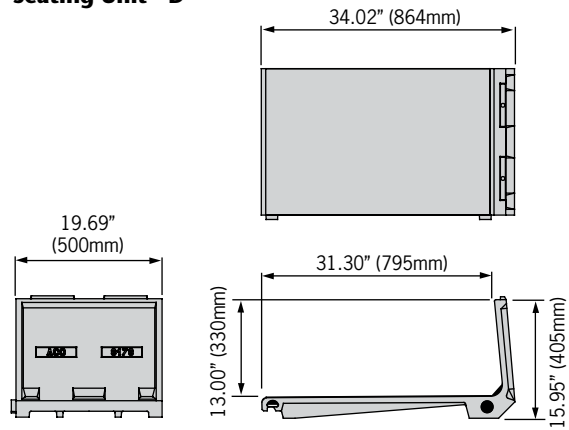

Seating Unit - 1/2 section - E

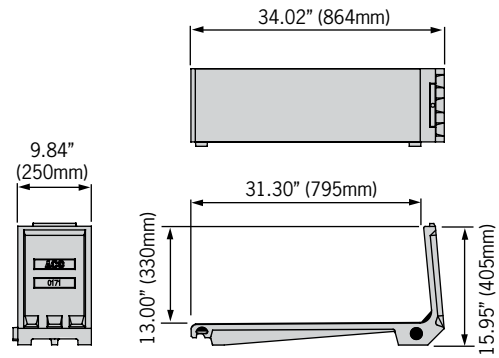

Top Plate - F

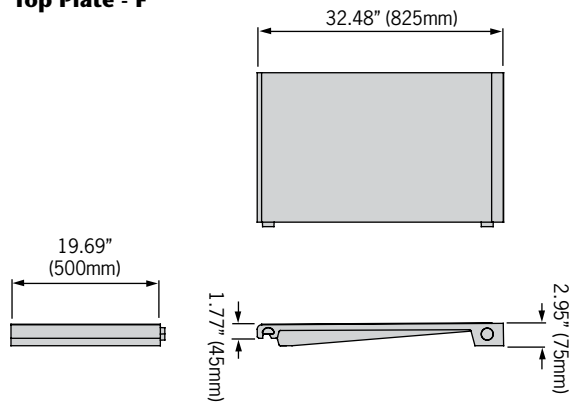

Top Plate - 1/2 section - G

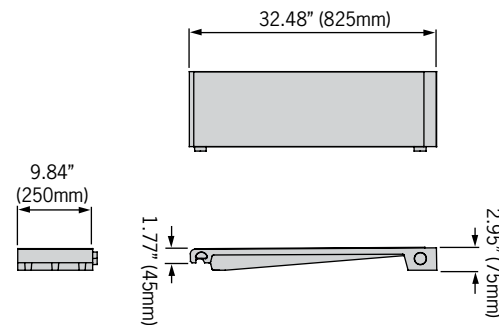

Front Plate - H

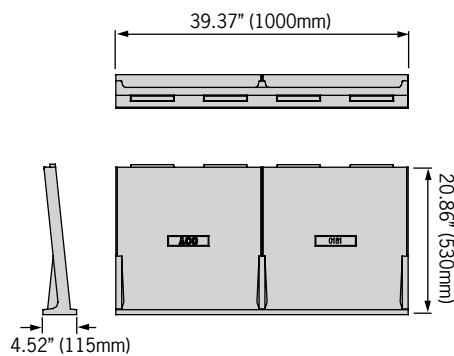

End Fill-in Plates

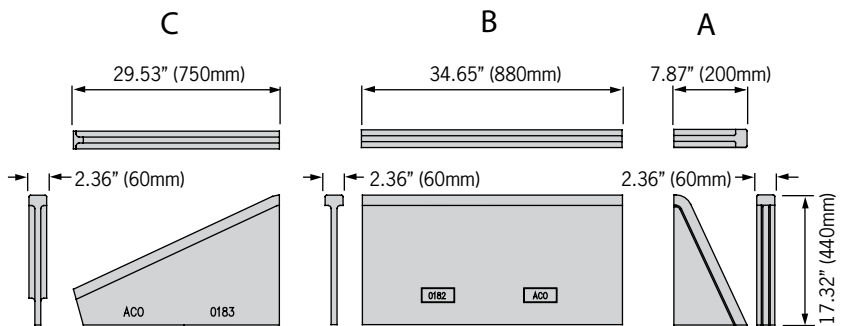

ACO Specification Information



ACO SPORT

System 9000 Bleacher seating system

ACO Specification Information

Step Elements

Step Unit - I

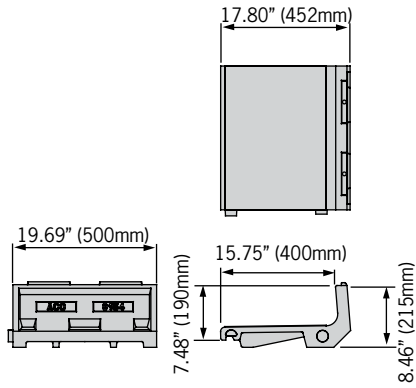

Step Unit - 1/2 section - J

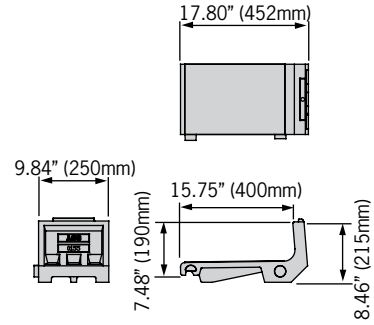

Top Plate - K

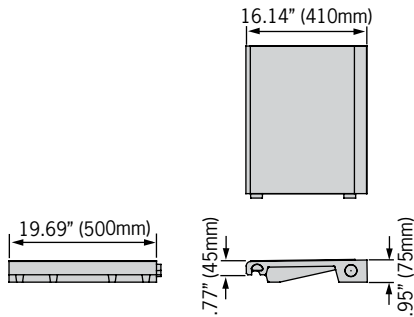

Top Plate - 1/2 section - L

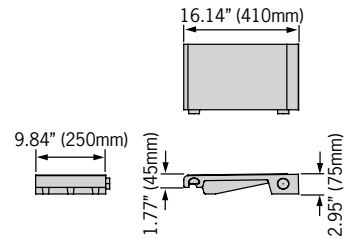

Front Plate - M

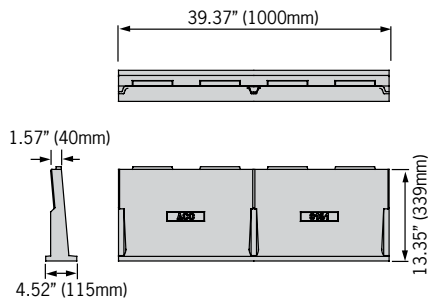

End Fill-in Plates

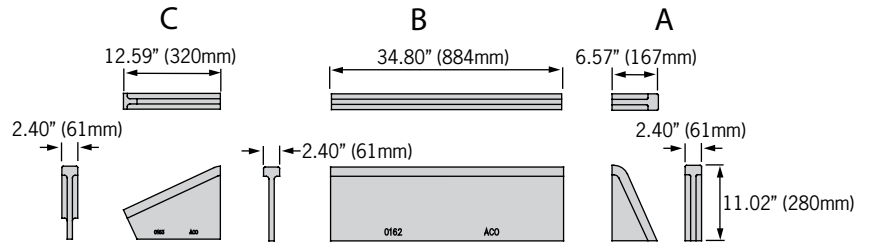

Transition components - use at transition between steps and seats - N

Left Plate

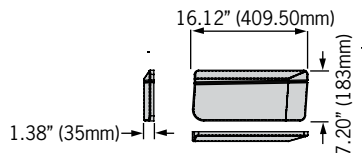

Right Plates

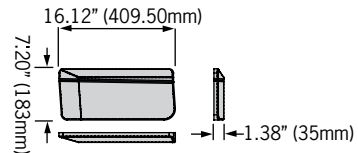

System 9000 Bleacher seating system

	Part No.	Length in. (mm)	Width in. (mm)	Height in. (mm)	Wgt (lbs)
Step components					
Front plate (M)	00161	39.4 (1000)	1.6 (40)	11.0 (280)	41.8
Standing unit (I)	00154	19.7 (500)	15.7 (400)	7.5 (190)	57.2
Standing unit- 1/2 section (J)	00155	9.8 (250)	15.7 (400)	7.5 (190)	28.6
Top plate (K)	00165	19.7 (500)	15.0 (380)	2.9 (75)	33.0
Top plate - 1/2 section (L)	00166	9.8 (250)	15.0 (380)	2.9 (75)	17.6
Lower fill-in plate (A)	00164	5.9 (150)	2.4 (60)	11.0 (280)	4.4
Middle fill-in plate (B)	00162	34.7 (880)	2.4 (60)	11.0 (280)	30.8
Top fill-in plate (C)	00163	13.4 (340)	2.4 (60)	11.0 (280)	8.8
Transition components (N)					
Side fill-in plate (right)	00194	16.5 (420)	1.2 (30)	7.5 (190)	6.6
Side fill-in plate (left)	00208	16.5 (420)	1.2 (30)	7.5 (190)	6.6
Seating components					
Front plate (H)	00181	39.4 (1000)	1.6 (40)	18.9 (480)	61.6
Seating unit (D)	00170	19.7 (500)	31.5 (800)	15.0 (380)	94.6
Seating unit- 1/2 section (E)	00171	9.8 (250)	31.5 (800)	15.0 (380)	46.2
Top plate (F)	00186	19.7 (500)	30.7 (780)	2.9 (75)	66.0
Top plate - 1/2 section (G)	00187	9.8 (250)	30.7 (780)	2.9 (75)	35.2
Lower fill-in plate (A)	00184	7.9 (200)	2.4 (60)	17.3 (440)	8.8
Middle fill-in plate (B)	00182	34.7 (880)	2.4 (60)	17.3 (440)	66.0
Top fill-in plate (C)	00183	29.5 (750)	2.4 (60)	17.3 (440)	24.2

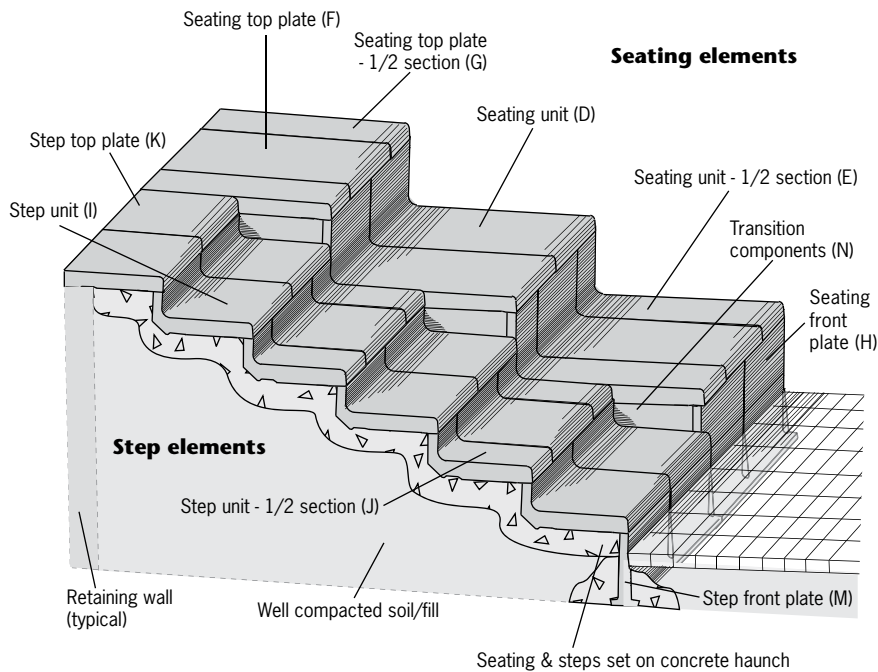

ACO SPORT

Part I - General

- 1.1 **Related Work** - Work specified in other sections includes but is not limited to: Excavation and backfill, cast-in-place concrete, and mechanical equipment.
- 1.2 **System Description** - bleacher seating system from corrosion resistant polyester polymer concrete for on-site installation.
- 1.3 **Submittals** - Manufacturer will submit, when required, shop drawings showing schematic plan of bleacher system listing all parts being provided for installation. Copies of the manufacturer's recommended method of installation and assembly shall be submitted for review.
- 1.4 **Project History** - Manufacturer shall submit a list of projects installed during the past twenty years, if required.
- 1.5 **Warranty** - ACO provides a limited warranty of one year based on installation according to manufacturer's installation instruction data.

Part II - Product

- 2.1 **Products** - Manufacturer shall be ACO Polymer Products, Inc.
- 2.2 **Physical & Mechanical Characteristics**
 - Overall width - varies as multiple pieces fit together to fit site requirements
 - Overall depth - varies as multiple pieces fit together to fit site requirements

Note: designs should not go higher than 12.5ft high, which equates to approximately 20 step or 10 seating elements.

 - Compressive strength - 14,000 psi
 - Flexural strength - 4,000 psi
 - Water absorption rate - <0.1% by weight
- 2.3 **Bleacher Profile** - Shall include rounded edges and anti-slip surface texture. Pre-cast polymer concrete units are supplied in 500mm (19.69") or 250mm (9.84") sections. Front plates are used at the ground level and top plates are used at the highest points to close off the system. Side fill-in plates close the openings left at the transition between step and seat sections. End fill-in plates finish the outside edges of the bleacher system.

Part III - Installation

- 3.1 **Site Preparation** - Check ground conditions of area where bleachers are to be installed. Ground must be stable & engineering advice is strongly recommended. Ground should be prepared with an overall 6% slope. Stepped levels can be prepared. ACO recommends a maximum height of 20 standing elements or 10 seating elements.
- 3.2 **Installation**
 - **Front Plates** - Position on 4" concrete bed. Ensure sections are level & vertical. Haunch both sides with concrete to hold securely in place. Lay land drainage (perforated) pipe behind front plates, along entire length, to reduce head pressure from water accumulation. Backfill with clean fill to level of 4" below top of front plate & compact.
 - **Seating/Standing Elements** - Lay 4" stiff mix concrete base on top of compacted fill so it is level with top of front plates. Position seating/standing elements onto concrete base. Ensure elements overlap joints of front plates. Check elements have slight (approx. 1%) forward slope to facilitate drainage. Before positioning next element, backfill to height 4" below top of previous element & compact. Lay 4" concrete base on top of backfill so that it is level with top of previous element. Position next seating/standing elements onto concrete base, overlapping joints. Check elements have slight (1%) forward slope. Continue until final seating/standing elements are installed.
 - **Top Plates** - Backfill final seating/standing elements to height 4" below top of previous element & compact. Lay 4" concrete base on top of backfill so it's level with top of final elements & position top plates.
 - **Fill-in Plates** - open faces between seating & standing elements should be concrete rendered. Side fill-in plates can be attached using ACO Bond Kit.
 - **Expansion Joints** - ACO recommends expansion joints, approx. every 30 ft. - saw cut and fill with flexible sealant.
- 3.3 **Finishing and Clean-up** - Following final set of concrete, remove protection covering the top of each water jump section.
- 3.4 **Install in strict accordance with manufacturer's recommendations and drawings. Details available at www.acousa.com/install_drawings_sport.htm**

ACO Polymer Products, Inc.

East Sales Office

P.O. Box 245
Chardon, OH 44024
Tel: (440) 285-7000
Toll free: (800) 543-4764
Fax: (440) 285-7005

West Sales Office

P.O. Box 12067
Casa Grande, AZ 85130
Tel: (520) 421-9988
Toll Free: (888) 490-9552
Fax: (520) 421-9899

Follow us on



Electronic Contact:

info@acousa.com
www.acousa.com

