

Type 847D/848D Longitudinal Stainless Steel Grate (ADA) Spec Sheet

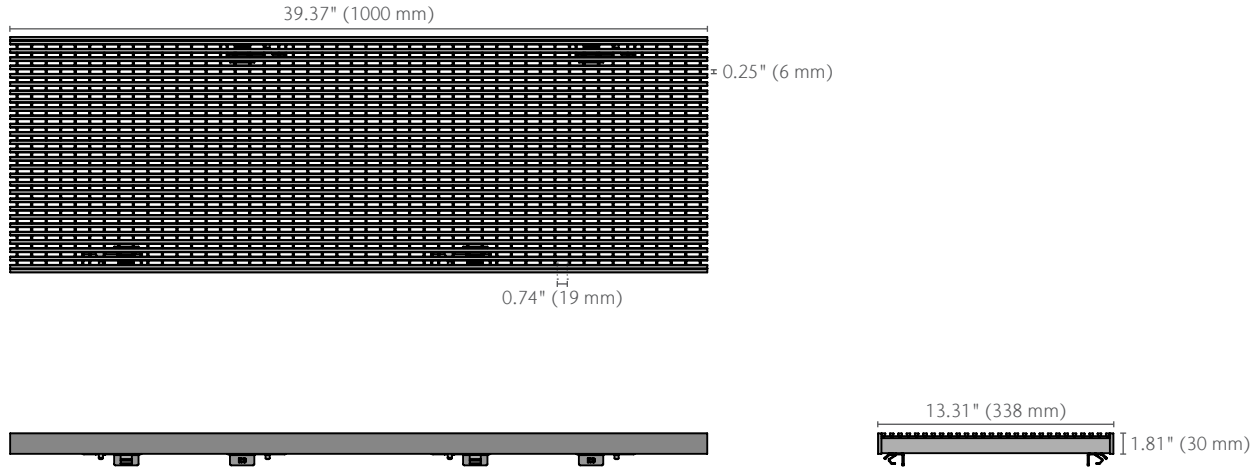

Type 847D Longitudinal Stainless Steel Grate

part no. 142223



Product Name	Part No.	Length in (mm)	Width in (mm)	Weight lbs
Type 847D Longitudinal Stainless Steel Grate (ADA)	142223	39.37 (1000)	13.31 (338)	28.6
Type 848D Longitudinal Stainless Steel Grate (ADA)	142224	19.69 (500)	13.31 (338)	14.5

Type 847D/848D Longitudinal Stainless Steel Grate (ADA) Spec Sheet



DrainLok Locking Mechanism

ACO DrainLok is a patented, boltless locking system that removes the need for bolts and bars while improving the hydraulic capacity of the channel. DrainLok Clips lock into the channel's edge rail for rapid installation. ACO DrainLok grates are fitted with an anti-shunt mechanism that restricts unwanted grate movement when installed, improving durability and longevity of the system.

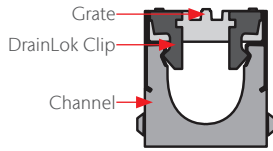

Specification Summary

General

The surface drainage system shall be ACO Drain K300, KS300, or H300K-13, channels complete with ACO Type 847D/848D Longitudinal (ADA compliant) Stainless Steel grate with DrainLok locking as manufactured by ACO, Inc. or similar approved.

Installation

The trench drain system and grates shall be installed in accordance with the manufacturer's installation instructions and recommendations.

Materials

The covers shall be manufactured from stainless steel and have minimum properties as follows:

- 16 gauge, Grate 304 stainless steel
- Intake area of 131.6 in² (848.99.0 cm²) per half meter of grate
- Intake area of 192 in² (1238.7 cm²) per half meter of grate

Type 847D has a width of 13.31" (338 mm) and length of 39.37" (1000 mm).
Type 848D has a width of 13.31" (338 mm) and length of 19.69" (500 mm).
Slots measure at 0.81" (20.57 mm) by 0.24" (6.09 mm).

ADA-compliant per The Americans with Disabilities Act of 2010, Section 302.3

ASME: A112.6.3 : Section 7.12
Heel-resistant Strainers & Grates
grate hole size ≤ 0.31" (8 mm)

ACO Heel-safe standard:
grate hole size ≤ 0.25" (6.5 mm)

Australian Standard AS 3996 - 2006 Clause 3.3.6:
max slot length dependent on slot width for grates that are deemed Bicycle Tire Penetration Resistant.

EN1433 Load Class A
3,372 lbs – 70 psi

ACO, Inc.

© January 2026 ACO, Inc.

All reasonable care has been taken in compiling the information in this document. All recommendations and suggestions on the use of ACO products are made without guarantee since the conditions of use are beyond the control of the company. It is the customer's responsibility to ensure that each product is fit for its intended purpose and that the actual conditions of use are suitable. ACO, Inc. reserves the right to change products and specifications without notice.

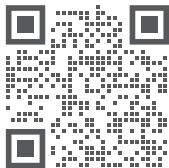

info@acousa.com
www.acousa.com

