

# FG200 Ductile Iron Slotted Grate Spec Sheet

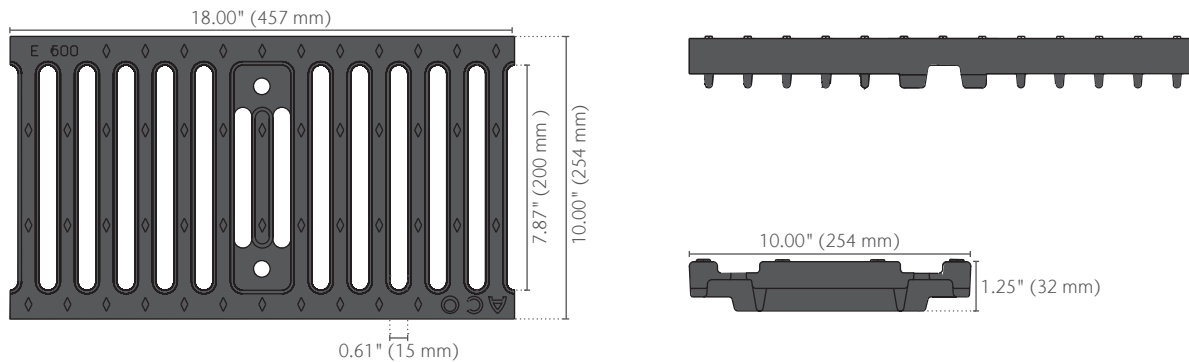

## FG200 Ductile Iron Slotted Grate

part no. 93896



Product Name

FG200 Ductile Iron Slotted Grate  
Replacement Stainless Steel Hex Head Bolts (Qty 2)

Part No.

93896  
93892

Length  
in (mm)

18.00 (457)  
-

Width  
in (mm)

10.00 (254)  
-

Weight  
lbs

28.7  
0.2

### Specification Summary

General

The surface drainage system shall be ACO Drain FG200 channels complete with ACO FG200 ductile iron slotted grate with boltlocking as manufactured by ACO, Inc. or similar approved.

Grates

Grate is slotted ductile iron. Ductile iron ASTM 536 - Grade 80-55-06. After removal of the grates there shall be uninterrupted access to the trench to aid maintenance.

Installation

The trench drain system and grates shall be installed in accordance with the manufacturer's installation instructions and recommendations.

Materials

The covers shall be manufactured from ductile iron and have minimum properties as follows:

- Ductile iron to ASTM 536 - Grade 80-55-06.
- Intake area of 58.7 in<sup>2</sup> (378.7 cm<sup>2</sup>) per 18" of grate.

The overall width of 10.00" (254 mm) and overall length of 18.00" (457 mm). Slots measure 7.87" (200 mm) by 0.61" (15 mm).



EN1433 Load Class F  
202,328 lbs – 4,177 psi



200,000 lb Proof Load

### ACO, Inc.

© January 2026 ACO, Inc.

All reasonable care has been taken in compiling the information in this document. All recommendations and suggestions on the use of ACO products are made without guarantee since the conditions of use are beyond the control of the company. It is the customer's responsibility to ensure that each product is fit for its intended purpose and that the actual conditions of use are suitable. ACO, Inc. reserves the right to change products and specifications without notice.

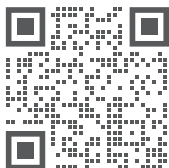

info@acousa.com  
www.acousa.com

