

# Single Wye Spec Sheet

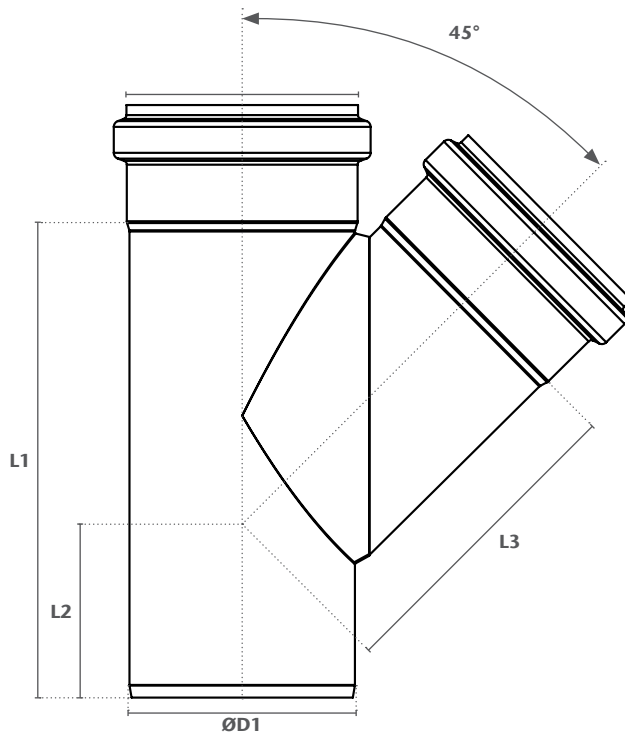

Part No.	Length (L1) in (mm)	Length (L2) in (mm)	Length (L3) in (mm)	ØD1 in (mm)	Gasket Material	Pipe Material	Weight lbs
417372	4.65 (118)	2.29 (58)	2.49 (63)	1.57 (40)	EPDM	316L	0.7
98798	5.04 (128)	2.25 (57)	3.00 (76)	1.97 (50)	EPDM	316L	0.7
98850	7.05 (179)	2.92 (74)	4.34 (110)	2.95 (75)	EPDM	316L	1.5
98852	9.18 (233)	3.47 (88)	5.87 (149)	4.33 (110)	EPDM	316L	2.7
419762	10.75 (273)	4.06 (103)	6.70 (170)	4.92 (125)	EPDM	316L	4.0
98854	13.08 (332)	7.25 (184)	11.89 (302)	6.30 (160)	EPDM	316L	7.1
419429	16.34 (415)	5.95 (151)	10.79 (274)	7.87 (200)	EPDM	316L	13.0
417108	20.20 (513)	6.78 (172)	13.23 (336)	9.84 (250)	EPDM	316L	19.6
417209	24.26 (616)	7.68 (195)	20.52 (521)	12.40 (315)	EPDM	316L	45.3

## Specification Summary

Used with ACO Pipe System. Made from AISI 316L. Resistant to thermal and dynamic shocks. Rodent-proof and sagproof. Non-combustible. Double-lipped seal push-fit connection. Designed for gravity piping system with maximum working pressure of 0.5 bar. Socket clamps, NBR and FPM gasket material also available upon request. Socket clamp can increase maximum operating pressure to 0.7 bar.

ACO recommends checking local plumbing codes prior to installation. Manufactured to EN 1124-1 and 1124-2.

## ACO, Inc.

© January 2026 ACO, Inc.

All reasonable care has been taken in compiling the information in this document. All recommendations and suggestions on the use of ACO products are made without guarantee since the conditions of use are beyond the control of the company. It is the customer's responsibility to ensure that each product is fit for its intended purpose and that the actual conditions of use are suitable. ACO, Inc. reserves the right to change products and specifications without notice.

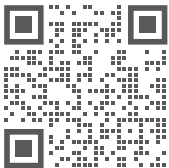

info@acousa.com  
www.acousa.com

